

# Handheld Acoustic Camera



HZ-HA-171

HZ-HA-171 is a high sensitivity acoustic imaging system specifically engineered for the detection of partial discharge(Optional) issues in high-voltage electrical systems and the gas leaks in compressed gas systems.

Boasting an array of 128 MEMS microphones, this sophisticated system excels in detecting and quantifying various instances of partial discharge while also providing accurate estimations of gas leak rates and associated costs.

As the world's lightest acoustic camera, it's perfect for inspectors and professionals to swiftly identify efficiency loss and potential failures.

Driven by Hertzinno's AI engine, the system offers intuitive operation, reducing training time and ensuring ease of use.

## Key Features

- 128 MEMS Microphones
- 2kHz ~ 65kHz detection
- Supports multiple source detection
- Real-time sound source localization
- Real-time partial discharge type prediction(Optional)
- Real-time estimate gas leak rate, leak cost



## ■ Specification

<b>Model</b>	<b>HZ-HA-171p</b>
<b>Acoustic</b>	
Microphones	128 Microphones
Dynamic Range of Camera	-30dB ~ 120dB
Dynamic Range of Sensor	30dB ~ 120dB
Minimum Imaging Sensitivity	10 kHz: 25 dB SPL 20 kHz: 14 dB SPL 30 kHz: 15 dB SPL 40 kHz: 18 dB SPL 50 kHz: 4 dB SPL 60 kHz: 38dB SPL
Operating Distance	0.3m ~ 150m
Horizontal Spatial Resolution	150mm
Dynamic Range of multiple targets	0 ~ 18dB
Frequency Bandwidth	2kHz ~ 65kHz
Microphone Self-diagnosis	Support
<b>General</b>	
Camera	5MP
FOV	64°
Photo Image Resolution	1920*1080/800*480
Imaging Frame	25FPS/ Video Frame 11FPS
Digital Zoom	3x digital
Video Image Resolution	800*480@11FPS
Storage	Internal 64GB
Video record	5min
Display	800*480P, 5-inch Capacitive Touch Screen
Wi-Fi	2.4G/5G
USB	TYPE-C
Battery Operating Time	7h
Replaceable Battery	YES
Direct Charging Type	NA
Protection Level	IP51
Weight	Approx. 1100g
Dimension	315mm* 167mm* 74.35mm
Working Temperature Range	-20°C ~ 50 °C
Storage Temperature Range	-30°C ~ 60 °C
Humidity	10% -95%
<b>Applications</b>	
Application Scenarios	Gas leakage
Leaks Rate	> 0.83ml/s, @120kpa from 6m

## ■ Available model

HZ-HA-171

## ■ Dimension

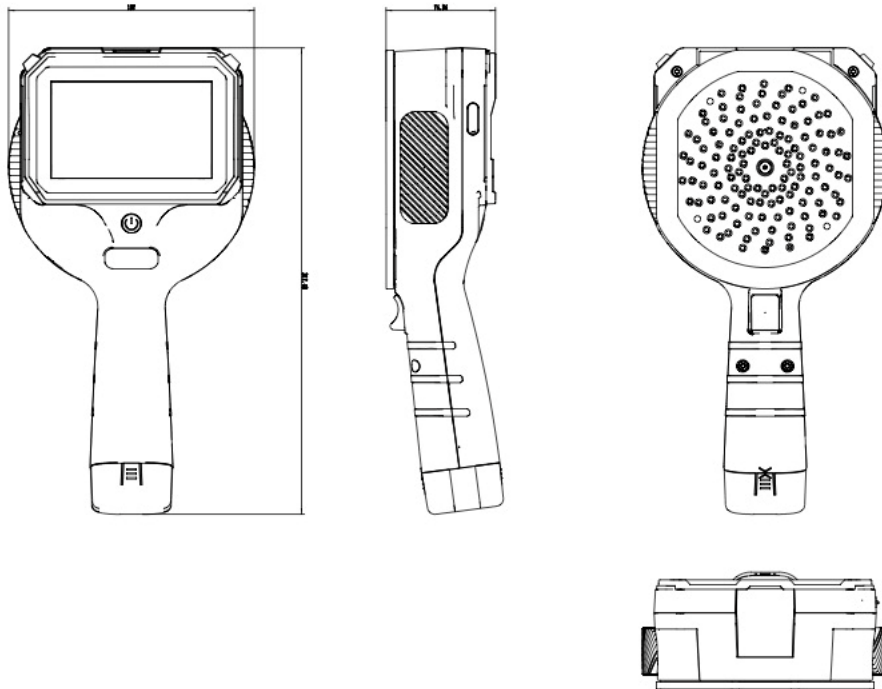

## ■ Packaging list

1. Acoustic Imaging Camera
2. DC 12V Charging
3. Spare Battery
4. Charger docker
5. Carrying Case
6. User Manual
7. Factory test report
8. Accessory kit

## ■ Notes

Parameters are subject to change, please refer to Hertzinno's official announcement.  
Hertzinno reserves the right of final explanation for any changes.